

# Drilling



## Features:

- Sharp nose for increased penetration
- Offered in a Hybrid tip, or Plug tip for impact and highly abrasive material
- Interchangeable series offers flexibility

Tool Part Number	Shank (in, mm)	Tip Diameter (in, mm)	Gauge (in, mm)	Pieces per Box	Pieces per Pallet
DR35	1.0 in 25 mm	0.476 in 12.1 mm	2.5 in 64.0 mm	35	2100
DR73	1.0 in 25 mm	0.591 in 15.0 mm	2.5 in 64.0 mm	35	2100
DR74	1.0 in 25 mm	0.708 in 17.9 mm	2.5 in 64.0 mm	35	2100
DR75	1.0 in 25 mm	.817 in 20.75 mm	2.5 in 64.0 mm	35	2100
DR76	1.0 in 25 mm	0.930 in 23.62 mm	2.5 in 64.0 mm	35	2100

Block Part Number	Bore Hole Diameter (in, mm)	Width (in, mm)	Angle (degrees)	Internal Groove	Pieces per Box	Pieces per Pallet
B25LN	1.012 in 25.71 mm	1.72 in 43.7 mm	45°	Yes	15	900
B25H	1.012 in 25.71 mm	1.72 in 43.7 mm	45°	Yes	8	480

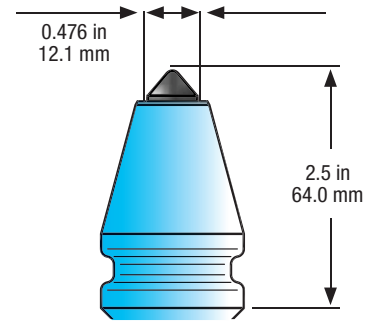

**DR35**

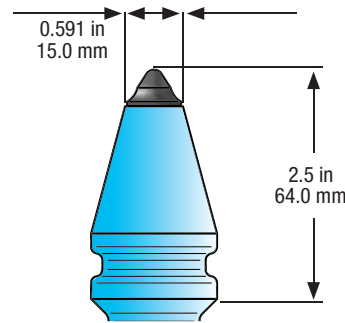

**DR73**

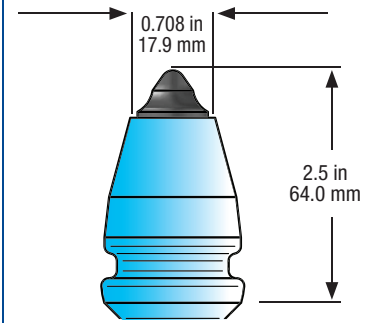

**DR74**

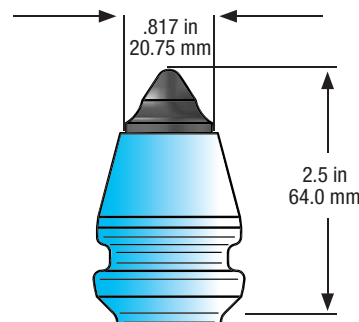

**DR75**

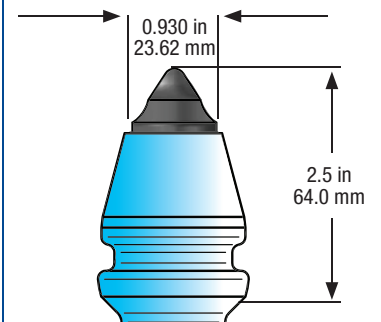

**DR76**

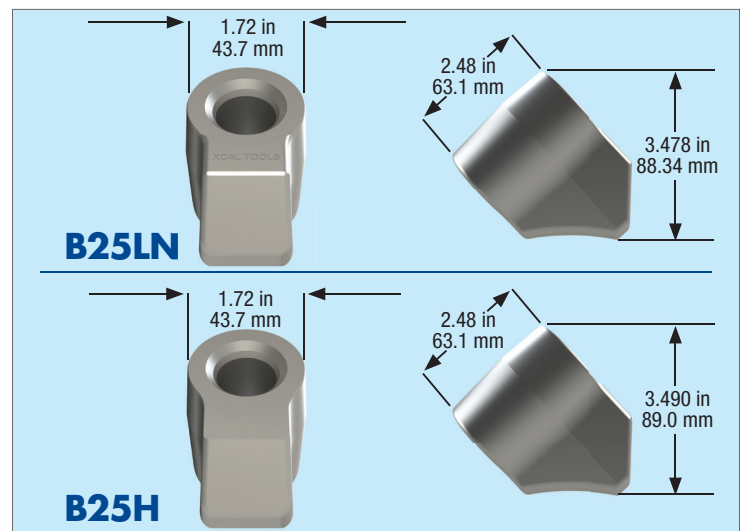

**B25LN**

**B25H**



Proudly made in the U.S.A.

