

# Drilling

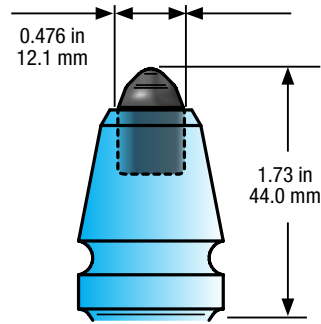

**TC403L**  
Carbide Plug

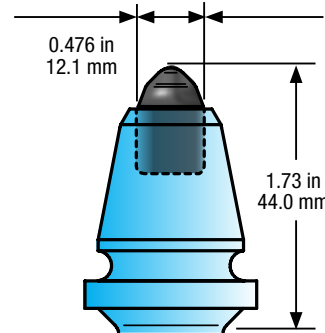

**TC403**  
Carbide Plug

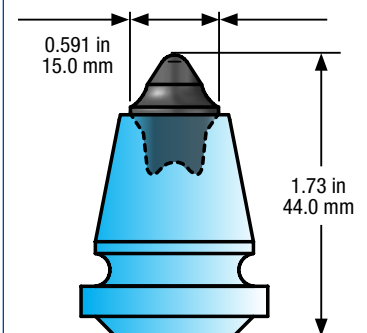

**TC473**  
Carbide Hybrid  
(Plug/Valve Seat)

## Features:

- Standard body design
- Used for Core Barrels and Augers
- Puller groove for easy tool removal
- Offered with a Wedding Band or Sleeve retainer

Tool Part Number	Shank (in, mm)	Shoulder (in, mm)	Tip Diameter (in, mm)	Gauge (in, mm)	Pieces per Box	Pieces per Pallet
TC403L	0.74 in 19.0 mm	1.06 in 27.0 mm	0.476 in 12.1 mm	1.73 in 44.0 mm	65	3900
TC403	0.74 in 19.0 mm	1.25 in 31.75 mm	0.476 in 12.1 mm	1.73 in 44.0 mm	65	3900
TC473	0.74 in 19.0 mm	1.25 in 31.75 mm	0.591 in 15.0 mm	1.73 in 44.0 mm	65	3900

Block Part Number	Bore Hole Diameter (in, mm)	Width (in, mm)	Angle (degrees)	Internal Groove	Pieces per Box	Pieces per Pallet
B19L45	.782 in 19.87 mm	1.375 in 34.9 mm	45°	Yes	35	2100
B19H45	.782 in 19.87 mm	1.624 in 41.28 mm	45°	Yes	35	2100
B19HT45	.782 in 19.87 mm	1.654 in 42.0 mm	45°	Yes	20	900

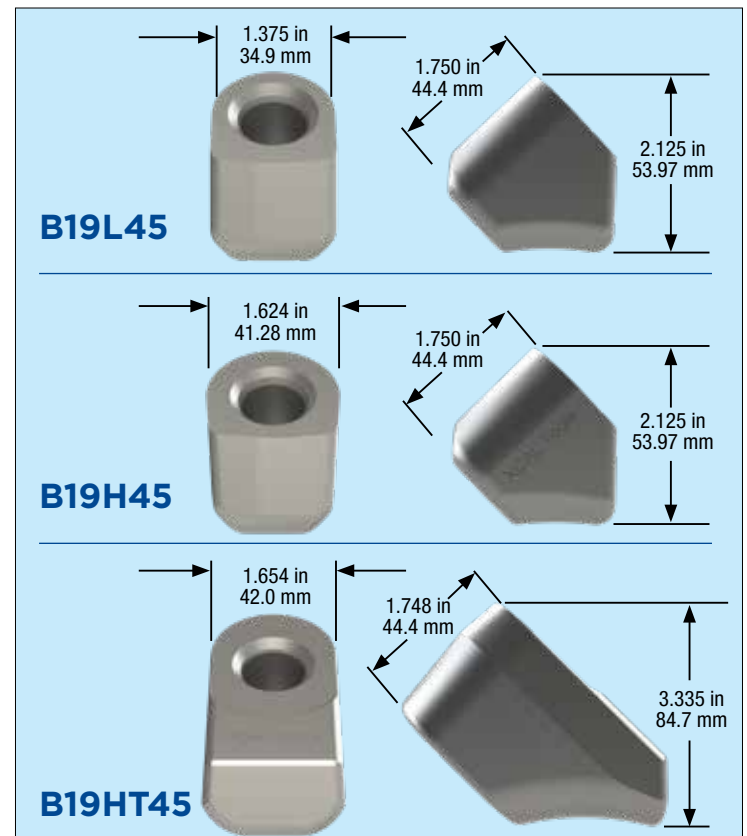

Proudly made in the U.S.A.